



地址：山东省聊城市开发区军王屯工业园  
电话：0635-8533278  
传真：0635-8533278  
网址：www.luyang.com  
邮编：252000

Add: Junwangtun Industrial Park, Liaocheng Development  
Zone, Shandong, China PC:252000  
Tel: 0086-635-8533278  
Fax: 0086-635-8533278  
Http: www.luyang.com

版权所有聊城鲁阳型材有限公司，保留所有权利。

未经书面许可，本手册内容不得被复制或抄袭用于任何目的。

商标及图形标志为注册商标。

本手册所涉及的全部资料和内部图片均归鲁阳型材版权所有，仿冒必究。

鲁阳型材保留更改产品外观、规格、参数的权利，恕不另行通知，本手册仅供参考，最终订货以实物为准。

印刷可能使资料内部产品与实物有所差别，所有资料经过仔细校对，如有任何印刷错漏，本公司不承担因此产生的后果，公司保留对资料内有关内容的最终解释权。

LUYANG-2020-11 版



**鲁阳型材**  
**LUYANG PROFILE**

**PVC PROFILE**

INTEGRATED MANUFACTURER

塑钢型材 · 集成制造商

中国环保优质建材

ISO9001:2015 质量管理体系认证

ISO14001:2015 环境管理体系认证



聊城鲁阳型材有限公司  
LiaoCheng LuYang PVC Profile Co., Ltd.



**做优质环保建材 · 创百年诚信品牌**

始创于 1999 年的优秀品牌

Make high-quality environmental protection building materials and  
create a hundred-year honest brand

Excellent brand founded in 1999

用鲁阳型材 · 做优质门窗

Make high-quality doors & windows  
with Luyang profiles

+

整合优势技术资源 · 持续推动产品升级  
致力于为门窗行业提供优质型材及专业服务

Committed to providing high-quality profiles and professional services  
for the door and window industry



安全可靠  
Safe and Reliable



专业高效  
Professional Efficient



持续创新  
Continuous Innovation

## 诚信赢天下 实干闯未来

Honesty wins the world and works hard to create the future

世界有多辽阔，心灵就有多辽阔。

天地之间，精彩无处不在，人生百年，何不笑傲豪迈。在钢筋水泥的丛林中，灰色成为压抑人们心绪的情结，但人们自有心比天高的志趣。鲁阳型材，正视自己在建筑中实效与装饰兼备的重要地位，以装点时尚空间为己任，以呵护人、愉悦人为职责，以演绎无限精彩生活为最高目标，聊城鲁阳型材厂注重科技、质量及人力资源的发展，以适应不断发展的社会需求。

“保护资源，呵护健康，创造人类美好生活”这一定位体现了鲁阳的宗旨，让人们开启心灵之窗是最大的心愿，这也是鲁阳追求发展的目标。

鲁阳做的不仅仅是产品，更是您的安全与健康。鲁阳的每一支型材采用绿色环保配方，欧洲先进的生产工艺，行业领先的数字化生产线精制而成，品质让您无可挑剔。

鲁阳人将持续创新，竞争中坚持品质，为您提供更优质的产品与服务，期待与您真诚合作、携手并进、共创辉煌！

As vast as the world is, so vast is the soul.

Between heaven and earth, wonderful is everywhere, life is a hundred years, why not be proud and heroic? In the reinforced concrete jungle, gray has become a complex that depresses people's mood, but people have their own lofty aspirations. Luyang profile, facing up to its important position of both effectiveness and decoration in architecture, takes the responsibility of decorating fashionable space, takes care of people and delights people as its duty, and takes the interpretation of infinite wonderful life as its highest goal. Liaocheng Luyang profile factory pays attention to the development of science and technology, quality and human resources in order to meet the ever-developing social needs.

The orientation of "protecting resources, caring for health and creating a better life for mankind" embodies Luyang's aim, and it is the greatest wish for people to open the window of the soul, which is also the goal of Luyang's pursuit of development.

Luyang is not only a product, but also your safety and health. Each profile of Luyang is made of green environmental protection formula, advanced European production technology and industry-leading digital production line, and its quality makes you impeccable.

Luyang people will continue to innovate, insist on quality in competition, provide you with better products and services, and look forward to sincere cooperation with you, hand in hand and create brilliant future!

## CONTENTS | 目录

### ABOUT US 关于鲁阳 01 | 12

企业简介	01/02
企业文化	03/04
荣誉证书	05/06
检测报告	07/08
生产实力	09/10
质量保证	11/12

### PRODUCT ADVANTAGE 产品优势 13 | 24

鲁阳产品的五大优势	13/14
70平开系列优势特点	15/16
65平开系列优势特点	17/18
60平开系列优势特点	19/20
88推拉系列优势特点	21/22
80推拉系列优势特点	23/24

### SECTION OF PROFILE 型材断面 25 | 35

70平开系列断面米重	25/25
65平开系列断面米重	26/27
60平开系列断面米重	28/29
88推拉系列断面米重	30/31
80推拉系列断面米重	32/35

### PROCESSING FLOW 加工指南 36 | 38

门窗下料尺寸计算说明	36/36
多样化窗型	37/38

### ENGINEERING CASE 工程案例 39 | 44

鲁阳型材部分工程案例	39/42
鲁阳服务体系	43/44



## Company profile

### 企业简介

鲁阳型材位于景色秀丽的“江北水城”山东聊城，是生产研发门窗用未增塑（PVC-U）型材和塑料门窗的大型企业，始创于1999年，是我国研发生产PVC-U型材最早的企业之一，拥有国内最先进的数字化型材挤出生产线和业内领先的质量检测设备。通过多年的精心研发，现有定型产品：门窗用60/65/70平开系列、80/88推拉系列，表面处理多元化，有白色、双色共挤、胶条共挤、覆膜、拉丝、压花等型材供广大用户选择，也可根据用户个性化需求量身定制。

鲁阳型材始终把产品质量视为企业生命，坚持以优质的产品、满意的服务、持续改进的产品质量、满足用户需求为方针，建厂当年就通过了ISO9001国际质量体系认证，并严格按照ISO9001质量认证要求实施生产经营，保证了产品质量长期稳定过硬，受到广大用户的一致好评，并先后荣获“国家免检产品”、“中国名优产品”、“山东省建机行业名牌产品”、“中国环保优质建材”、“中国建筑施工首选建材”、“建设部推荐产品”、“中国市场放心建材”、“全国百佳质量过硬企业”、“聊城市优秀建材产品”等多项殊荣。产品畅销山东、河北、河南、北京、天津、山西、内蒙等地。

鲁阳型材不断实现产品的品质升级与技术革新，将推出更多、更新、更好的产品，致力打造优秀品牌，成为行业绿色发展的先行者。

专业的视角 选择专业的鲁阳  
鲁阳型材 -- 矢志成为您最佳的合作伙伴

## Luyang profiles

### Determined to be your best partner

Luyang profile is located in Liaocheng, Shandong Province, which is a beautiful "Jiangbei Shuicheng". It is a large-scale enterprise that produces and develops unplasticized (PVC-U) profiles for doors and windows and plastic doors and windows. Founded in 1999, Luyang profile is one of the earliest enterprises that develop and produce PVC-U profiles in China. It has the most advanced digital profile extrusion production line in China and the leading quality inspection equipment in the industry. Through years of careful research and development, the existing products are 60/65/70 flat opening series and 80/88 push-pull series for doors and windows, with diversified surface treatments. There are profiles such as white, two-color co-extrusion, rubber strip co-extrusion, film coating, wire drawing and embossing, which can be customized according to the individual needs of users.

Luyang profile always regards product quality as the life of the enterprise, and adheres to the principle of high-quality products, satisfactory service, continuous improvement of product quality and meeting the requirements of users. It passed the ISO9001 international quality system certification in the year when it was built, and implemented production and operation in strict accordance with the requirements of ISO9001 quality certification, thus ensuring long-term stable and excellent product quality, which won unanimous praise from users.

Luyang profile continuously realizes product quality upgrade and technical innovation, and will launch more, newer and better products, and strive to build excellent brands, and become the pioneer of green development in the industry.

鲁阳人用爱关怀，用心耕耘，为更辉煌的明天共同奋斗  
我们注重企业精神，更注重社会责任

## Luyang profiles

We pay more attention to the spirit of enterprise and social responsibility

每一个目标的达成  
不是任务的终结  
而是新的开始  
为更高的理想努力奋斗  
是鲁阳不变的信念

The achievement of every goal  
Not the end of the mission  
But a new beginning  
Strive for a higher ideal  
It is Luyang's unchanging belief



## Corporate culture 企业文化

### CORPORATE PURPOSE 企业宗旨

做优质环保建材·创百年诚信品牌  
Make high-quality building materials and create honest brand

### ENTERPRISE POLICY 企业方针

科技先导·质量为本·高效管理·创新发展  
Science and Technology Leading, Quality Oriented, Innovative Development

### DEVELOPMENT PRINCIPLE 发展原则

高定位·高品质·高层次  
发展中完善·完善中发展  
High positioning, high quality and high level  
Perfection in development

### QUALITY OBJECTIVE 质量目标

求品质·树名牌·创效益  
Seeking Quality, Building Famous Brands and Creating Benefits

### ENTERPRISE SPIRIT 企业精神

诚信务实·开拓进取  
Honesty, pragmatism, pioneering and enterprising

### QUALITY POLICY 质量方针

科技领先·高效优质  
Leading technology, high efficiency and high quality

### BUSINESS PHILOSOPHY 经营理念

诚信赢天下·实干闯未来  
用鲁阳型材·做优质门窗  
Honesty wins the world and works hard to create the future

### SERVICE CONCEPT 服务理念

服务为先·诚信为本·为用户创造价值  
Service First, Integrity First  
Create Maximum Value for Users

# Certificate honor

## 荣誉证书

- ISO9001 质量管理体系认证
- ISO14001 环境管理体系认证
- 中国名优产品
- 山东省建机行业名牌产品
- 中国环保优质建材
- 中国建筑施工首选建材
- 建设部推荐产品
- 中国市场放心建材
- 全国百佳质量过硬企业
- 聊城市优秀建材产品
- .....
- ISO9001 quality management system certification
- ISO14001 environmental management system certification
- Chinese famous products
- Famous brand products of construction machinery industry in Shandong
- China environmental protection quality building materials
- The first choice of building materials in China's construction
- Products recommended by the Ministry of Construction
- China market assured building materials
- National Top 100 Excellent Quality Enterprises
- Liaocheng excellent building materials products
- .....



逐风雨而成长，只有经历风雨，才有彩虹邂逅  
汗水成就梦想，荣誉见证辉煌

# Luyang profiles

## Sweat makes dreams, honor witnesses glory



# Authoritative detection

## 权威检测

我们的全系产品均通过权威机构检测合格，部分性能指标优于国标或行业标准，完全能满足用户节能要求，强度及健康标准。

All our products have passed the inspection by authoritative organizations, and some performance indexes are better than national standards or industry standards, which can fully meet the energy-saving requirements, strength and health standards of users.

- ☛ 60 平开系列通过权威检验合格
- ☛ 65 平开系列通过权威检验合格
- ☛ 70 平开系列通过权威检验合格
- ☛ 80 推拉系列通过权威检验合格
- ☛ 88 推拉系列通过权威检验合格

- ☛ 60 flat open series passed the authoritative inspection
- ☛ 65 flat open series passed the authoritative inspection
- ☛ 70 flat open series passed the authoritative inspection
- ☛ 80 push-pull series passed the authoritative inspection
- ☛ 88 push-pull series passed the authoritative inspection



我们不断前行，寻求更完美的解决方案  
通过权威检测，可信赖的品质

# Luyang profiles

## Through authoritative testing, reliable quality



**Production strength**  
生产实力

批量化、规范化，确保订单保质保量如期交货  
领先的智控设备，专业的技术团队

## **Luyang profiles**

Leading equipment and professional technical team

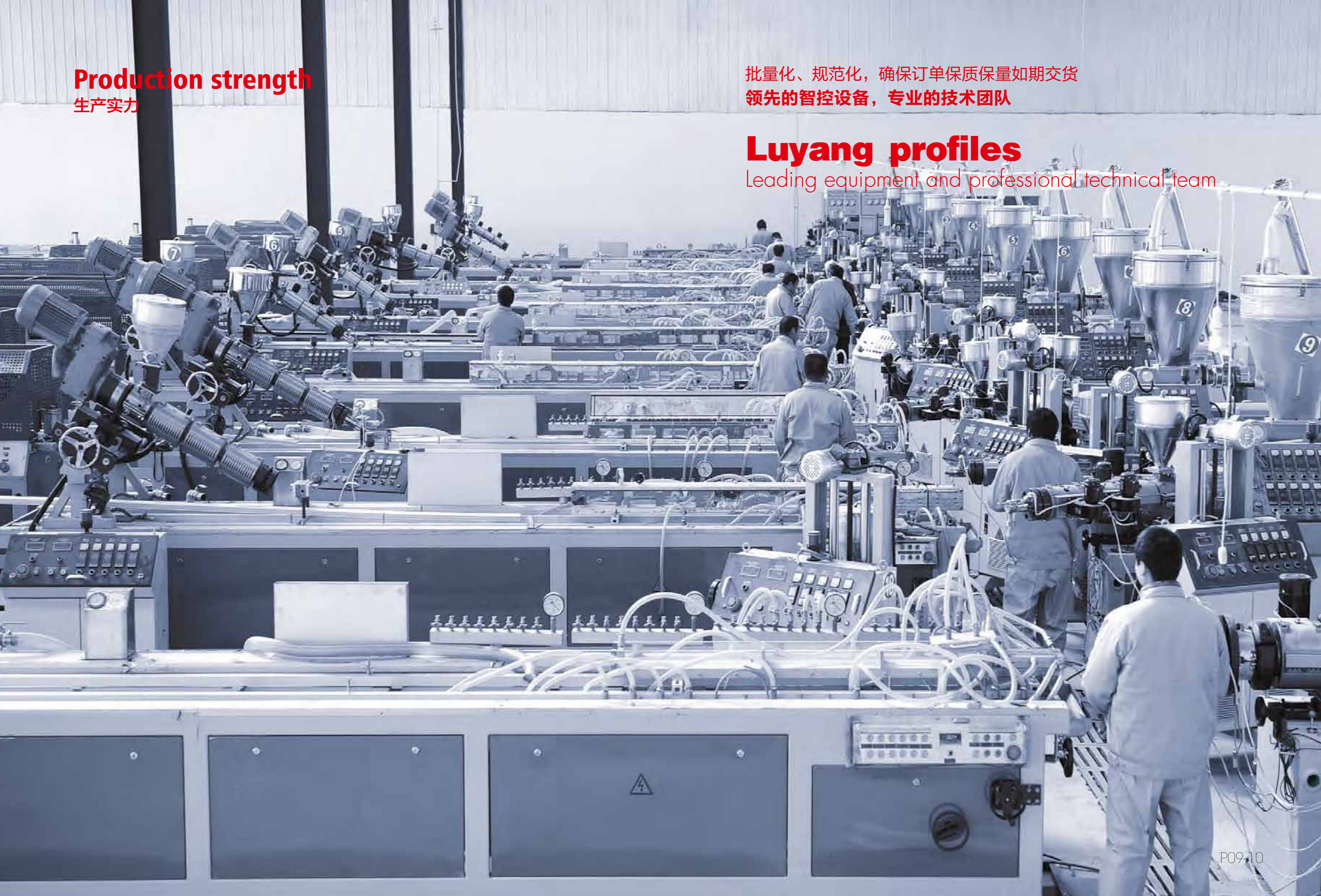

**Quality assurance**  
质量保证



以高于行业标准制造和检验每一件产品，确保品质  
专业的检测设备，完善的检测流程

## Luyang profiles

Professional testing equipment and perfect process

鲁阳对产品质量的要求坚持一种严苛的态度，追求完美。在多年经验的积累下，建立了完善的质量控制体系，并引进行业领先的质量检测设备。从原材料的采购、产品设计、生产制造、成品存储、产品销售到技术支持的全过程质量管理，每支型材都要经历严格的质检程序，将产品质量控制到最优，对每一细微之处都要求精益求精，让用户使用到最完美的鲁阳型材。

Luyang adheres to a strict attitude towards product quality and pursues perfection. After years of experience, we have established a perfect quality control system and introduced industry-leading quality inspection equipment. From purchasing raw materials, designing, manufacturing, storing and selling finished products to quality management in the whole process of technical support, each profile has to go through strict quality inspection procedures to control the product quality to the best, and strive for perfection in every detail, so that users can use the most perfect Luyang profile.



# Performance advantages

## 鲁阳产品优势

我们的 **5** 大优势 · 是您专业的选择

Our five advantages are your professional choice

01



### 多腔结构截面，保温、隔热、隔音性能优异

鲁阳型材截面为多腔结构，设计科学合理，具有独立的排水腔、钢衬腔、完全使水和钢衬隔离，积水无法进入钢衬腔，最大限度延长了门窗使用寿命，合理的多腔结构隔离设计，从而有效的提高了门窗的保温、隔热、隔音性能。

Luyang profile section is multi-cavity structure, and the design is scientific and reasonable, thus effectively improving the heat preservation, heat insulation and sound insulation performance of doors and windows.

02



### 塑胶共挤带胶条，省工、省时、密封好

鲁阳型材塑胶共挤工艺实现了胶条与型材一体化生产，使密封胶条与型材连接牢固不脱落，胶条连接处不断头，提高了门窗的气密、水密性能，更有效的提高了门窗的保温、隔热、隔音性能。门窗加工时省工、省时节约人工成本。

Luyang profile has realized the integrated production of rubber strip and profile, which makes the connection between sealing rubber strip and profile firm and does not fall off, and the joint of rubber strip does not break, thus saving labor, time and labor cost when processing doors and windows.

03



### 表面多样化处理，色彩、花纹丰富

鲁阳型材表面先进的多元化色彩处理工艺，配有双色共挤、拉丝、压花、覆膜等表面色彩花纹的产品。设计理念超前，成品美观实用，产品表面平整、光滑、色彩亮丽，提高了耐磨和抗划痕性能，可解决色彩装饰的全程设计方案，更可满足各种档次及个性化的需求。

Apply advanced diversified surface treatment technologies and treatment technologies of colorful surface design such as two-tone co-extrusion, wire drawing, embossing and laminating. With advancing design concept, beautiful and utility finished products and smooth.

04



### 绿色配方更安全，无毒无味不易燃

鲁阳型材配方中全部选用无毒、无味、无害、无污染的优质绿色环保原料，合理添加阻燃剂，使型材具有健康安全，绿色环保，不挥发有害气体，不易燃、能自熄、不导电等安全性。

In the formula of Luyang profile, all the high-quality green environmental protection raw materials which are non-toxic, tasteless, harmless and pollution-free are selected, and the flame retardant is reasonably added, so that the profile has the safety of health, safety, environmental protection, non-volatilization of harmful gases, non-flammability, self-extinguishing and non-conductivity.

05



### 用料优，耐老化、寿命长

鲁阳型材采用优质原材料和国际领先的生产工艺，可使门窗在寒冷、暴晒、潮湿、风沙以及有化学污染的恶劣环境下不老化、不脆化、不变形，门窗使用寿命可达 50 年以上。

Luyang profile adopts high-quality raw materials and international leading production technology, which can make doors and windows not aging, embrittlement and deformation in the harsh environment of cold, sun exposure, humidity, sand and chemical pollution, and the service life of doors and windows can reach more than 50 years.



# Product introduction

## 产品介绍

# 70

## 平开六腔三密封系列门窗型材 Flat Open Three-Seal Series

- 主型材为六腔结构，具有良好的保温、节能效果，是当前市场上最高档塑钢型材系列之一。
  - 采用独立的排水腔设计，增强了成窗排水性能。
  - 可设计成内平开窗、内开内倒窗、固定窗等。
  - 通过连接材料可组成任意角度连接。
  - 可以安装超大间距三层中空玻璃及双层中空玻璃。
  - 其工艺简单实用，可操作性强，适合工业化生产。
  - 可实现气密 4 级、水密 3 级、抗风压 4 级、保温 8 级的优异性能。
- 
- The main section bar with a six-cavity structure has good thermal-insulating and energy-saving effects, which is one of the most high-end section bar systems in the current market.
  - It applies independent drainage cavity design to improve the drainage performance of finished windows.
  - It can be designed into in-swinging casement windows, inward tilt-turn windows, fixed windows, etc.
  - Through connection materials, it can form connection in any angle.
  - It can be equipped with three-layer and double-layer hollow glass at large intervals.
  - With simple, utility and highly operable technologies, it is suitable for industrial production.
  - 4-level air tightness, 3-level water tightness, 4-level wind pressure resistance and 8-level thermal insulation.



# Product introduction

## 产品介绍

# 65

## 平开三密封系列门窗型材 Flat Open Three-Seal Series

- 65 平开系列针对高寒地区和高档建筑，该系列采用可视面厚度 B 类标准，满足门窗国标要求。
  - 大断面，大壁厚，保证了门窗的高强度；多腔室、可实现的三密封措施，完全满足节能的要求，是真正的保温专家。
  - 主型材为五腔室结构，保温性能优异；同时排水腔和钢衬腔分离设计，使钢衬的装配和水槽的加工相互独立，提高了门窗的使用寿命。
  - 当窗处于闭合状态时，框与扇之间有三道密封点，更能体现出窗的水密、气密的优越性，其保温性能比普通平开窗高两个等级，玻璃压条的标准设计，使得窗的框扇均可安装双玻或三玻。
- 
- Flat open 65 series in cold area and high-grade building, this series adopts visual surface thickness class B standard, To meet the national standard.
  - Large section and large thickness, high strength to ensure the doors and Windows; Chamber, which can realize the three sealing measures, fully meet the requirements of energy saving, insulation is a real expert.
  - Main profile for five chamber structure, heat preservation performance; Separation of steel lining and drainage cavity design at the same time, make the assembly of steel lining and sink processing are independent of each other, improve the service life of the doors and Windows.
  - Window in the closed state, with three seal between frame and door and better reflects the superiority of watertight, airtight window, glass bead standard design, make the sash of the window can be installed double glass or glass.



# Product introduction

## 产品介绍

# 60

## 平开系列门窗型材 Flat Open Series

- 60系列型材可与市场上五金件完美配套，制作各式各样的门窗，包括：固定窗、百叶窗、内平开窗、外平开窗、平开上悬窗、圆弧窗、平开门等，适用于各种建筑风格，满足您对塑钢门窗的需求。
  - 装有三元乙丙胶密封条，密封性更好。
  - 设有独立的排水腔、配套的纱扇型材、独特的毛条凹槽，使之密封性更加优越。
  - 型材的断面尺寸设计更加合理，满足了窗的受力要求。
  - 设有独立的排水腔、配套的纱扇型材、独特的毛条凹槽，使之密封性更加优越。
- 
- Series 60 profiles can be perfectly matched with the hardware on the market to produce various doors and windows, including: fixed windows, shutters, inner casement windows, outer casement windows, casement windows, circular arc windows, casement doors, etc., which are suitable for various architectural styles and meet your needs for plastic steel doors and windows.
  - With three EPDM sealing strip, the sealing performance is better.
  - There is an independent drainage cavity, supporting the gauze fan profiles, unique top groove, the sealing is more superior.
  - The design of profile section size is more reasonable, to meet the requirement of the force of the window.
  - It is equipped with independent drainage cavity, matching yarn fan profile and unique wool top groove, which makes its sealing performance more superior.



# Product introduction

## 产品介绍

# 88

## 推拉系列门窗型材 Push-pull Series

- 独特的设计和出众的实用性，深受广大客户喜爱，广泛应用于别墅、酒店、住宅、写字楼、医院、学校等多种类型建筑，能够满足较高的气密性、水密性、保温性能和隔声性能，提高居住环境的舒适性和生活、工作、学习的质量。
- 特殊结构的腔体和欧洲标准的五金件安装槽，方便了推拉门专用滑轮和高档锁具的使用。
- 宽大的玻璃安装空间，可安装不同规格要求的玻璃。
- 排水腔设计在外侧，与其他功能的腔体分隔，避免了相互间的渗透。
- 出材率高、窗形丰富，价格适中，制作方法简单。
- 抗风压强度高，完全适用于 10-25 层左右的建筑物。
- The unique design and outstanding practicability are deeply loved by our customers.
- They are widely used in villas, hotels, residential buildings, office buildings, hospitals, schools and other types of buildings. They can meet the requirements of high air tightness, water tightness, thermal insulation and sound insulation, and improve the comfort of living environment and the quality of life, work and study.
- The special structure of the cavity and the European standard hardware installation slot facilitate the use of special pulleys and high-grade locks for sliding doors.
- Wide glass installation space can be used to install glass with different specifications.
- The drainage cavity is designed at the outer side and is separated from other functional cavities to avoid mutual infiltration.
- High output rate, rich window shapes, moderate price and simple manufacturing method.
- The wind-resistant pressure is high, and is completely suitable for buildings with about 10 - 25 floors.



# Product introduction

## 产品介绍

# 80

## 推拉系列门窗型材 Push-pull Series

- 可制作高强度一体窗等多种窗型，满足高层建筑及其它建筑，各种固定框、转角、加强拼接材料等一应俱全。
  - 特殊结构的腔体和欧洲标准的五金件安装槽，方便了推拉门专用滑轮和高档锁具的使用。宽大的玻璃安装空间，可安装不同规格要求的玻璃。
  - 多腔型材结构设计，提高型材的保温、隔声作用，排水腔设计在外侧，与其他功能的腔体分隔，避免了相互间的渗透。
  - 出窗率高、窗形丰富，价格适中，制作方法简单。
  - 抗风压强度高，完全适用于 10-25 层左右的建筑物。
- 
- It can be used to make various window types such as high-strength integrated windows, etc. It can meet the needs of high-rise buildings and other buildings, and has all kinds of fixed frames, corners, reinforced splicing materials, etc.
  - The special structure of the cavity and the European standard hardware installation slot facilitate the use of special pulleys and high-grade locks for sliding doors. Wide glass installation space can be used to install glass with different specifications.
  - The structural design of multi-cavity profile improves the heat preservation and sound insulation effects of the profile. The drainage cavity is designed on the outer side and is separated from other functional cavities to avoid mutual penetration.
  - The invention has the advantages of high window outlet rate, rich window shapes, moderate price and simple manufacturing method.
  - The wind-resistant pressure is high, and is completely suitable for buildings with about 10 - 25 floors.





# Section of profile

## 型材截面

### 70

#### 平开三密封系列型材 Flat Open Three Sealed Series Cross Section of Profile

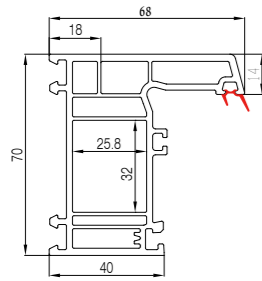
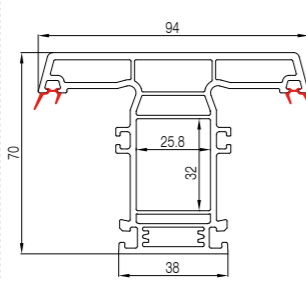
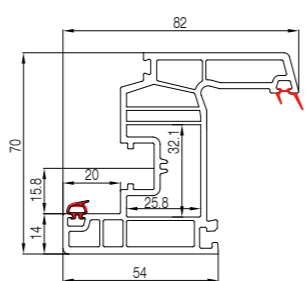
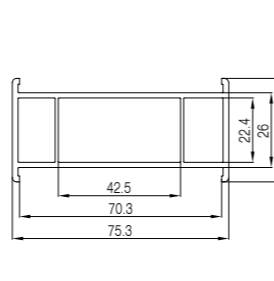
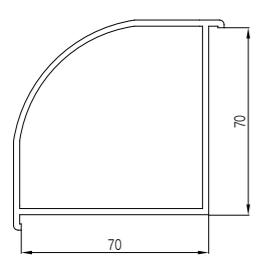
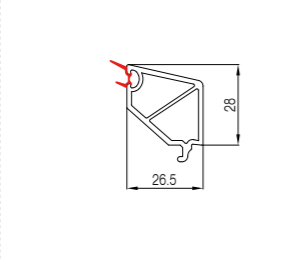
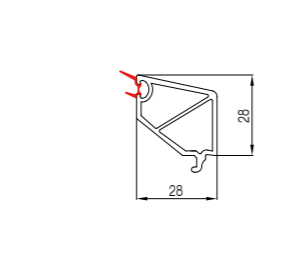
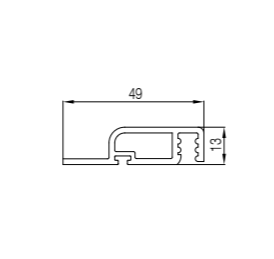
<p>70 平开框 70 Flat open frame P70-01</p>  <p>米重 Kg/m: 1.390 每包支数 pcs/pac: 6</p> <p>可共挤彩面 可共挤胶条 Co-extrusion color surface Coextrusion rubber strip</p>	<p>70 平开挺 70 Flat open mullion P70-02</p>  <p>米重 Kg/m: 1.670 每包支数 pcs/pac: 4</p> <p>可共挤彩面 可共挤胶条 Co-extrusion color surface Coextrusion rubber strip</p>	<p>70 内开扇 70 Inward sash P70-03</p>  <p>米重 Kg/m: 1.583 每包支数 pcs/pac: 4</p> <p>可共挤彩面 可共挤胶条 Co-extrusion color surface Coextrusion rubber strip</p>	<p>70 拼管 70 Spell tube P70-04</p>  <p>米重 Kg/m: 0.750 每包支数 pcs/pac: 8</p> <p>可共挤彩面 Co-extrusion color surface</p>
<p>70 转角 70 The corner P70-05</p>  <p>米重 Kg/m: 0.830 每包支数 pcs/pac: 4</p> <p>可共挤彩面 Co-extrusion color surface</p>	<p>70 双玻压条 26.5 70 Double glazing bead 26.5 P70-06</p>  <p>米重 Kg/m: 0.350 每包支数 pcs/pac: 10</p> <p>可共挤彩面 可共挤胶条 Co-extrusion color surface Coextrusion rubber strip</p>	<p>70 双玻压条 28 70 Double glazing bead 28 P70-07</p>  <p>米重 Kg/m: 0.350 每包支数 pcs/pac: 10</p> <p>可共挤彩面 可共挤胶条 Co-extrusion color surface Coextrusion rubber strip</p>	<p>70 纱扇 70 Screen sash P70-08</p>  <p>米重 Kg/m: 0.260 每包支数 pcs/pac: 16</p> <p>可共挤彩面 Co-extrusion color surface</p>

注: 本公司可能随时进行技术升级, 订货时按技术部提供的图纸为准, 图样重量为基材理论重量, 实际重量以过磅时的重量为准。

### 65

#### 平开三密封系列型材 Flat Open Three Sealed Series Cross Section of Profile

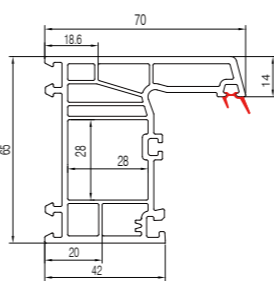
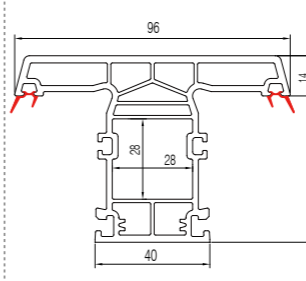
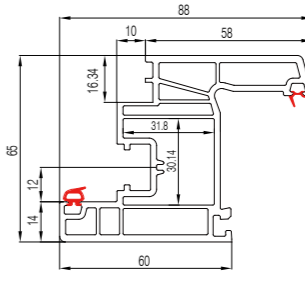
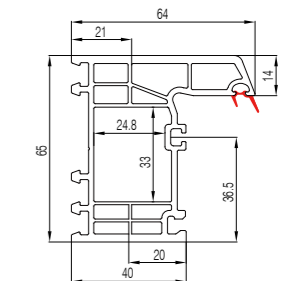
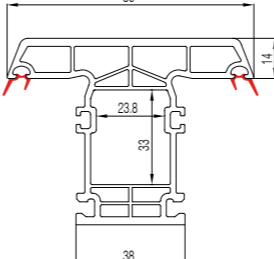
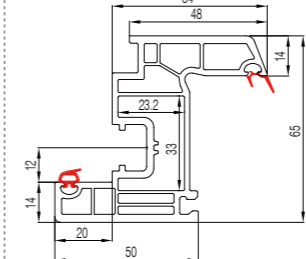
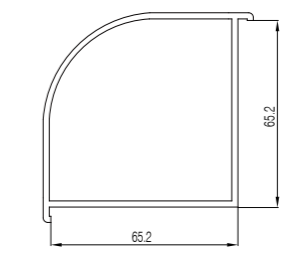
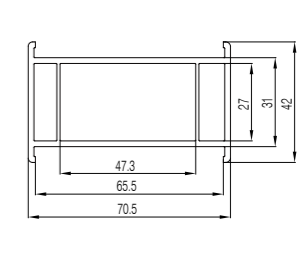
<p>65 平开框 -1 65 Flat open frame -1 P65-01</p>  <p>米重 Kg/m: 1.410 每包支数 pcs/pac: 6</p> <p>可共挤彩面 可共挤胶条 Co-extrusion color surface Coextrusion rubber strip</p>	<p>65 平开挺 -1 65 Flat open mullion -1 P65-02</p>  <p>米重 Kg/m: 1.670 每包支数 pcs/pac: 4</p> <p>可共挤彩面 可共挤胶条 Co-extrusion color surface Coextrusion rubber strip</p>	<p>65 内开扇 -1 65 Inward sash -1 P65-03</p>  <p>米重 Kg/m: 1.590 每包支数 pcs/pac: 4</p> <p>可共挤彩面 可共挤胶条 Co-extrusion color surface Coextrusion rubber strip</p>	<p>65 平开框 -2 65 Flat open frame -2 P65-04</p>  <p>米重 Kg/m: 1.280 每包支数 pcs/pac: 6</p> <p>可共挤彩面 可共挤胶条 Co-extrusion color surface Coextrusion rubber strip</p>
<p>65 平开挺 -2 65 Flat open mullion -2 P65-05</p>  <p>米重 Kg/m: 1.540 每包支数 pcs/pac: 4</p> <p>可共挤彩面 可共挤胶条 Co-extrusion color surface Coextrusion rubber strip</p>	<p>65 内开扇 -2 65 Inward sash -2 P65-06</p>  <p>米重 Kg/m: 1.400 每包支数 pcs/pac: 4</p> <p>可共挤彩面 可共挤胶条 Co-extrusion color surface Coextrusion rubber strip</p>	<p>65 转角 65 The corner P65-07</p>  <p>米重 Kg/m: 0.830 每包支数 pcs/pac: 4</p> <p>可共挤彩面 Co-extrusion color surface</p>	<p>65 拼管 65 Spell tube P65-08</p>  <p>米重 Kg/m: 0.750 每包支数 pcs/pac: 8</p> <p>可共挤彩面 Co-extrusion color surface</p>

注: 本公司可能随时进行技术升级, 订货时按技术部提供的图纸为准, 图样重量为基材理论重量, 实际重量以过磅时的重量为准。

# Section of profile

## 型材截面

### 65

#### 平开三密封系列型材

#### Flat Open Three Sealed Series Cross Section of Profile

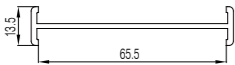
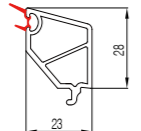
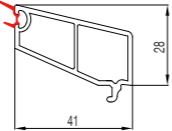
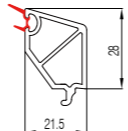
65 拼板 65 Spell plate P65- 09	65 双玻压条 65 Double glazing bead P65- 10	65 单玻压条 65 Single glazing bead P65- 11	65 三玻压条 65 Three glass battens P65- 12
			
米重 Kg/m: 0.292 每包支数 pcs/pac: 8	米重 Kg/m: 0.342 每包支数 pcs/pac: 10	米重 Kg/m: 0.400 每包支数 pcs/pac: 10	米重 Kg/m: 0.250 每包支数 pcs/pac: 12
可共挤彩面 Co-extrusion color surface	可共挤彩面 可共挤胶条 Co-extrusion color surface Coextrusion rubber strip	可共挤彩面 可共挤胶条 Co-extrusion color surface Coextrusion rubber strip	可共挤彩面 可共挤胶条 Co-extrusion color surface Coextrusion rubber strip

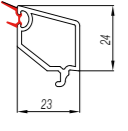
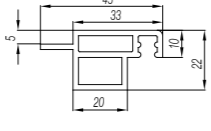
65 双玻压条 65 Double glazing bead P65- 13	65 纱扇 65 Screen sash P65- 14
	
米重 Kg/m: 0.342 每包支数 pcs/pac: 10	米重 Kg/m: 0.300 每包支数 pcs/pac: 16
可共挤彩面 可共挤胶条 Co-extrusion color surface Coextrusion rubber strip	可共挤彩面 Co-extrusion color surface

### 60

#### 平开系列型材

#### Flat Open Series Cross Section of Profile

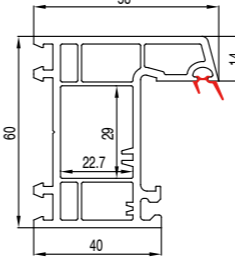
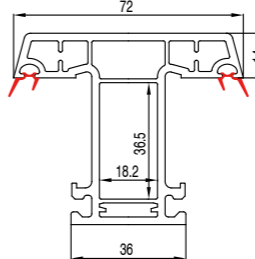
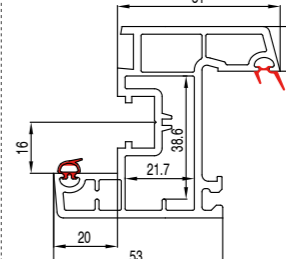
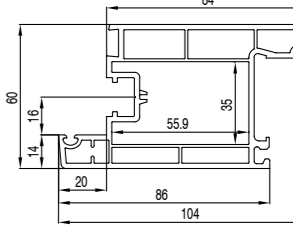
60 平开框 60 Flat open frame P60- 01	60 平开梃 60 Flat open mullion P60- 02	60 内开扇 60 Inward sash P60- 03	60 内开门扇 60 Flat open door frame P60- 04
			
米重 Kg/m: 1.170 每包支数 pcs/pac: 6	米重 Kg/m: 1.190 每包支数 pcs/pac: 6	米重 Kg/m: 1.230 每包支数 pcs/pac: 6	米重 Kg/m: 1.590 每包支数 pcs/pac: 4
可共挤彩面 可共挤胶条 Co-extrusion color surface Coextrusion rubber strip	可共挤彩面 可共挤胶条 Co-extrusion color surface Coextrusion rubber strip	可共挤彩面 可共挤胶条 Co-extrusion color surface Coextrusion rubber strip	可共挤彩面 可共挤胶条 Co-extrusion color surface Coextrusion rubber strip

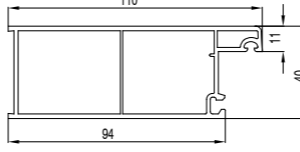
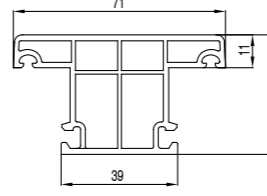
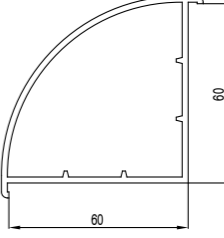
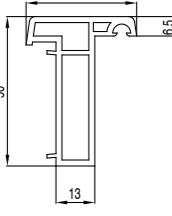
40 门扇 40 Door frame P60- 05	40 梃 40 Mullion P60- 06	60 转角 60 The corner P60- 07	40 浮中梃 40 Floating mullion P60- 08
			
米重 Kg/m: 1.000 每包支数 pcs/pac: 4	米重 Kg/m: 0.840 每包支数 pcs/pac: 5	米重 Kg/m: 0.750 每包支数 pcs/pac: 4	米重 Kg/m: 0.440 每包支数 pcs/pac: 10
可共挤彩面 可共挤胶条 Co-extrusion color surface Coextrusion rubber strip	可共挤彩面 可共挤胶条 Co-extrusion color surface Coextrusion rubber strip	可共挤彩面 Co-extrusion color surface	可共挤彩面 可共挤胶条 Co-extrusion color surface Coextrusion rubber strip

注: 本公司可能随时进行技术升级, 订货时按技术部提供的图纸为准, 图样重量为基材理论重量, 实际重量以过磅时的重量为准。

注: 本公司可能随时进行技术升级, 订货时按技术部提供的图纸为准, 图样重量为基材理论重量, 实际重量以过磅时的重量为准。

# Section of profile

## 型材截面

### 60

#### 平开系列型材 Flat Open Series Cross Section of Profile

60 拼管 60 Spell tube P60-09	60 拼板 60 Spell plate P60-10	60 单玻压条 37 60 Single glazing bead 37 P60-11	60 双玻压条 26.5 60 Double glazing bead 26.5 P60-12
米重 Kg/m: 0.710 每包支数 pcs/pac: 8 可共挤彩面 Co-extrusion color surface	米重 Kg/m: 0.195 每包支数 pcs/pac: 15 可共挤彩面 Co-extrusion color surface	米重 Kg/m: 0.284 每包支数 pcs/pac: 10 可共挤彩面 可共挤胶条 Co-extrusion color surface Coextrusion rubber strip	米重 Kg/m: 0.264 每包支数 pcs/pac: 12 可共挤彩面 可共挤胶条 Co-extrusion color surface Coextrusion rubber strip
60 纱扇 60 Screen sash P60-13	60 百叶框 60 Louver frame P60-14	60 百叶 60 Louver P60-15	15 门板 15 door panel P60-16
米重 Kg/m: 0.521 每包支数 pcs/pac: 8 可共挤彩面 Co-extrusion color surface	米重 Kg/m: 0.300 每包支数 pcs/pac: 10 可共挤彩面 Co-extrusion color surface	米重 Kg/m: 0.250 每包支数 pcs/pac: 10 可共挤彩面 Co-extrusion color surface	米重 Kg/m: 0.690 每包支数 pcs/pac: 7 可共挤彩面 Co-extrusion color surface

注: 本公司可能随时进行技术升级, 订货时按技术部提供的图纸为准, 图样重量为基材理论重量, 实际重量以过磅时的重量为准。

### 88

#### 推拉系列型材 Push-pull Series Cross Section of Profile

88 推拉框 88 Push-pull frame T88-01	88 双滑框 88 Double sliding frame T88-02	88 推拉扇 1 88 Push-pull sash 1 T88-03	88 推拉扇 2 88 Push-pull sash 2 T88-04
米重 Kg/m: 1.500 每包支数 pcs/pac: 4 可共挤彩面 Co-extrusion color surface	米重 Kg/m: 1.120 每包支数 pcs/pac: 6 可共挤彩面 Co-extrusion color surface	米重 Kg/m: 1.000 每包支数 pcs/pac: 8 可共挤彩面 可共挤胶条 Co-extrusion color surface Coextrusion rubber strip	米重 Kg/m: 0.920 每包支数 pcs/pac: 8 可共挤彩面 可共挤胶条 Co-extrusion color surface Coextrusion rubber strip
88 固定框 88 Push-pull fixed frame T88-05	88 固定框 88 Push-pull fixed frame mullion T88-06	88 扇框 88 Sash mullion T88-07	88 封边 88 Close over T88-08
米重 Kg/m: 1.110 每包支数 pcs/pac: 6 可共挤彩面 可共挤胶条 Co-extrusion color surface Coextrusion rubber strip	米重 Kg/m: 1.110 每包支数 pcs/pac: 6 可共挤彩面 可共挤胶条 Co-extrusion color surface Coextrusion rubber strip	米重 Kg/m: 0.770 每包支数 pcs/pac: 6 可共挤彩面 可共挤胶条 Co-extrusion color surface Coextrusion rubber strip	米重 Kg/m: 0.200 每包支数 pcs/pac: 10 可共挤彩面 Co-extrusion color surface



注: 本公司可能随时进行技术升级, 订货时按技术部提供的图纸为准, 图样重量为基材理论重量, 实际重量以过磅时的重量为准。

# Section of profile

## 型材截面

# 88

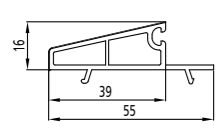
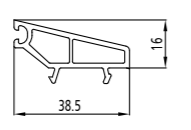
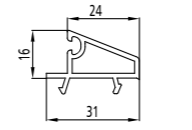
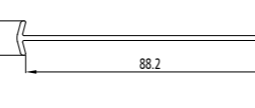
推拉系列型材  
Push-pull Series Cross Section of Profile

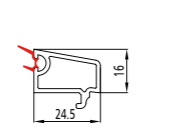
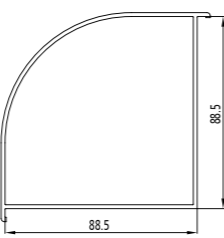
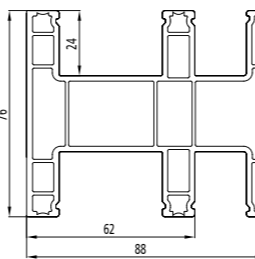
<p>88 支板 88 Support plate T88-09</p>  <p>米重 Kg/m: 0.317 每包支数 pcs/pac: 10</p> <p>可共挤彩面 可共挤胶条 Co-extrusion color surface Coextrusion rubber strip</p>	<p>88 框单压 88 Single glazing bead T88-10</p>  <p>米重 Kg/m: 0.284 每包支数 pcs/pac: 10</p> <p>可共挤彩面 可共挤胶条 Co-extrusion color surface Coextrusion rubber strip</p>	<p>88 框双压 88 Double glazing bead T88-11</p>  <p>米重 Kg/m: 0.233 每包支数 pcs/pac: 10</p> <p>可共挤彩面 可共挤胶条 Co-extrusion color surface Coextrusion rubber strip</p>	<p>88 拼板 88 Splice plate T88-12</p>  <p>米重 Kg/m: 0.300 每包支数 pcs/pac: 8</p> <p>可共挤彩面 Co-extrusion color surface</p>
<p>88 拼管 88 Tube splicing T88-13</p>  <p>米重 Kg/m: 0.710 每包支数 pcs/pac: 8</p> <p>可共挤彩面 Co-extrusion color surface</p>	<p>88 单玻压条 88 Single glazing bead T88-14</p>  <p>米重 Kg/m: 0.264 每包支数 pcs/pac: 12</p> <p>可共挤彩面 可共挤胶条 Co-extrusion color surface Coextrusion rubber strip</p>	<p>88 转角 88 The corner T88-15</p>  <p>米重 Kg/m: 1.000 每包支数 pcs/pac: 4</p> <p>可共挤彩面 Co-extrusion color surface</p>	<p>88 王字梃 88 Wang Zi mullion T88-16</p>  <p>米重 Kg/m: 1.830 每包支数 pcs/pac: 3</p> <p>可共挤彩面 Co-extrusion color surface</p>

注: 本公司可能随时进行技术升级, 订货时按技术部提供的图纸为准, 图样重量为基材理论重量, 实际重量以过磅时的重量为准。

# 80

推拉系列型材  
Push-pull Series Cross Section of Profile

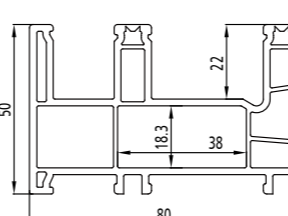
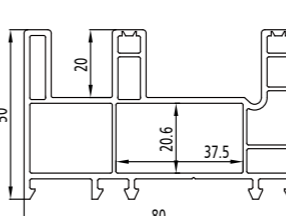
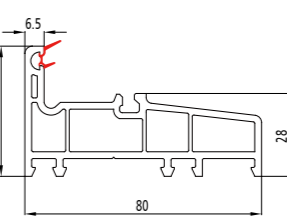
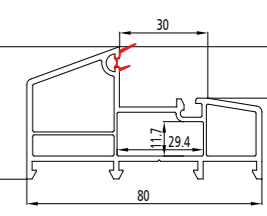
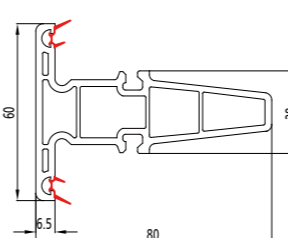
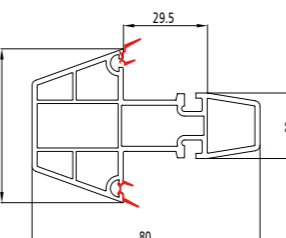
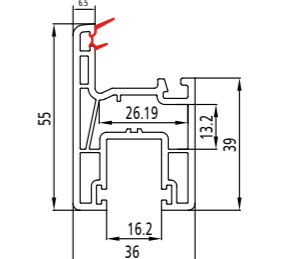
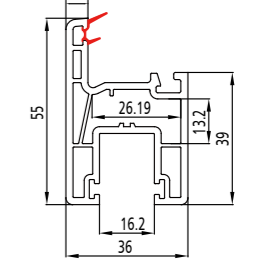
<p>80 推拉框 1 80 Push-pull frame 1 T80-01</p>  <p>米重 Kg/m: 1.300 每包支数 pcs/pac: 4</p> <p>可共挤彩面 Co-extrusion color surface</p>	<p>80 推拉框 2 80 Push-pull frame 2 T80-02</p>  <p>米重 Kg/m: 1.000 每包支数 pcs/pac: 4</p> <p>可共挤彩面 Co-extrusion color surface</p>	<p>80 固定框 1 80 Fixed frame 1 T80-03</p>  <p>米重 Kg/m: 0.990 每包支数 pcs/pac: 4</p> <p>可共挤彩面 可共挤胶条 Co-extrusion color surface Coextrusion rubber strip</p>	<p>80 固定框 2 80 Fixed frame 2 T80-04</p>  <p>米重 Kg/m: 0.860 每包支数 pcs/pac: 4</p> <p>可共挤彩面 可共挤胶条 Co-extrusion color surface Coextrusion rubber strip</p>
<p>80 固定梃 1 80 Fixed frame mullion 1 T80-05</p>  <p>米重 Kg/m: 1.030 每包支数 pcs/pac: 6</p> <p>可共挤彩面 可共挤胶条 Co-extrusion color surface Coextrusion rubber strip</p>	<p>80 固定梃 2 80 Fixed frame mullion 2 T80-06</p>  <p>米重 Kg/m: 1.000 每包支数 pcs/pac: 6</p> <p>可共挤彩面 可共挤胶条 Co-extrusion color surface Coextrusion rubber strip</p>	<p>80 扇 1 80 Sash 1 T80-07</p>  <p>米重 Kg/m: 0.690 每包支数 pcs/pac: 8</p> <p>可共挤彩面 可共挤胶条 Co-extrusion color surface Coextrusion rubber strip</p>	<p>80 扇 2 80 Sash 2 T80-08</p>  <p>米重 Kg/m: 0.790 每包支数 pcs/pac: 8</p> <p>可共挤彩面 可共挤胶条 Co-extrusion color surface Coextrusion rubber strip</p>

注: 本公司可能随时进行技术升级, 订货时按技术部提供的图纸为准, 图样重量为基材理论重量, 实际重量以过磅时的重量为准。

# Section of profile

## 型材截面

# 80

推拉系列型材  
Push-pull Series Cross Section of Profile

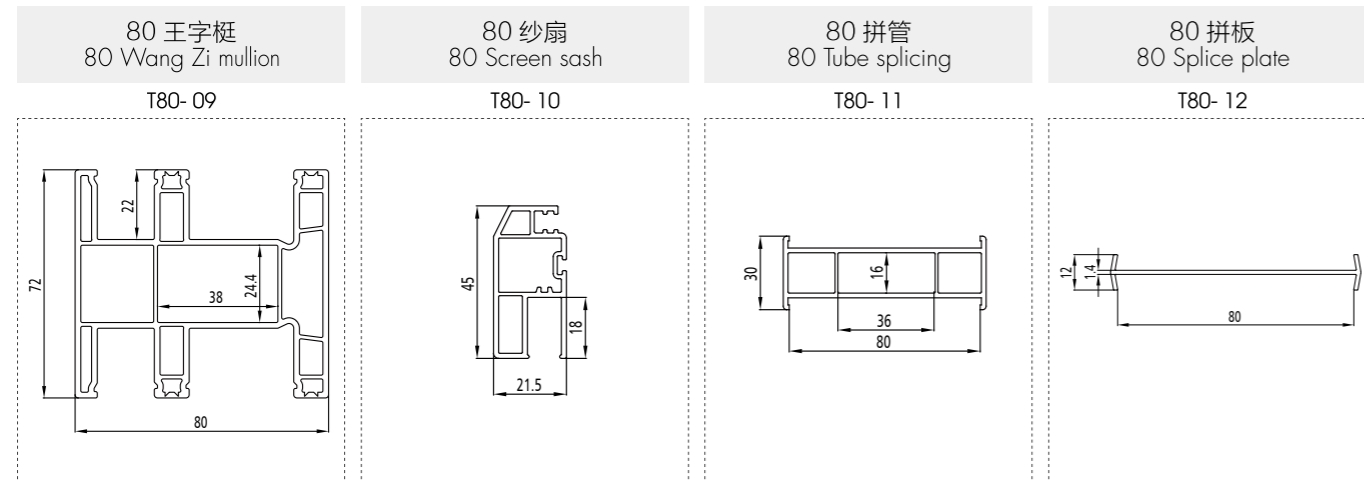

米重 Kg/m: 1.620  
每包支数 pcs/pac: 3

可共挤彩面  
Co-extrusion color surface

米重 Kg/m: 0.390  
每包支数 pcs/pac: 12

可共挤彩面  
Co-extrusion color surface

米重 Kg/m: 0.750  
每包支数 pcs/pac: 8

可共挤彩面  
Co-extrusion color surface

米重 Kg/m: 0.260  
每包支数 pcs/pac: 8

可共挤彩面  
Co-extrusion color surface

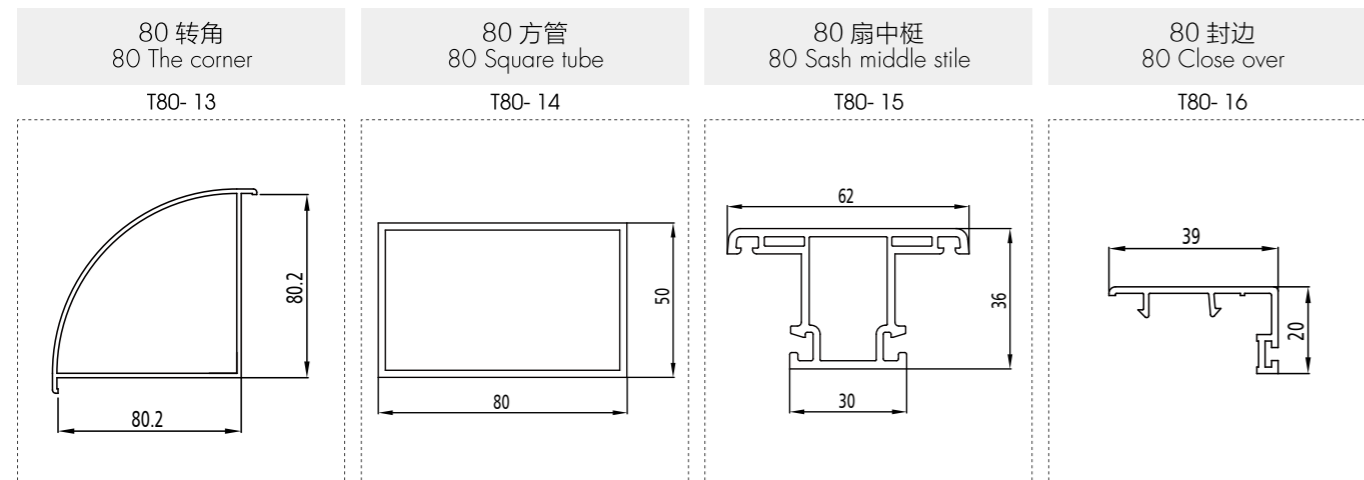

米重 Kg/m: 1.000  
每包支数 pcs/pac: 4

可共挤彩面  
Co-extrusion color surface

米重 Kg/m: 0.790  
每包支数 pcs/pac: 4

可共挤彩面  
Co-extrusion color surface

米重 Kg/m: 0.610  
每包支数 pcs/pac: 6

可共挤彩面  
Co-extrusion color surface

米重 Kg/m: 0.200  
每包支数 pcs/pac: 10

可共挤彩面  
Co-extrusion color surface

注: 本公司可能随时进行技术升级, 订货时按技术部提供的图纸为准, 图样重量为基材理论重量, 实际重量以过磅时的重量为准。

# 80

推拉系列型材  
Push-pull Series Cross Section of Profile

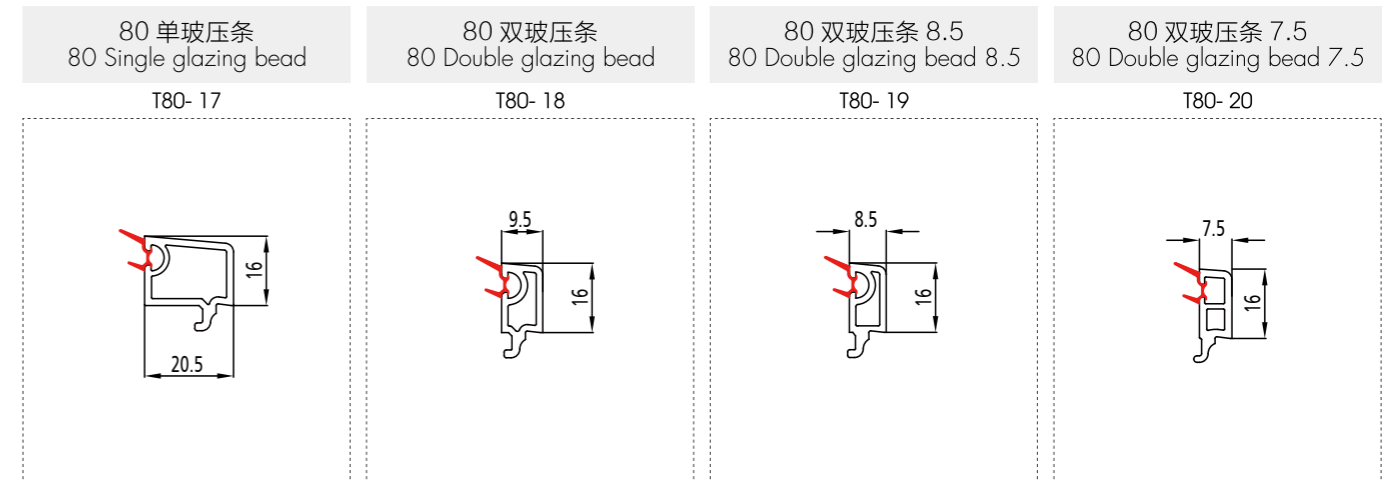

米重 Kg/m: 0.236  
每包支数 pcs/pac: 12

可共挤彩面 可共挤胶条  
Co-extrusion color surface  
Coextrusion rubber strip

米重 Kg/m: 0.175  
每包支数 pcs/pac: 20

可共挤彩面 可共挤胶条  
Co-extrusion color surface  
Coextrusion rubber strip

米重 Kg/m: 0.159  
每包支数 pcs/pac: 20

可共挤彩面 可共挤胶条  
Co-extrusion color surface  
Coextrusion rubber strip

米重 Kg/m: 0.159  
每包支数 pcs/pac: 20

可共挤彩面 可共挤胶条  
Co-extrusion color surface  
Coextrusion rubber strip

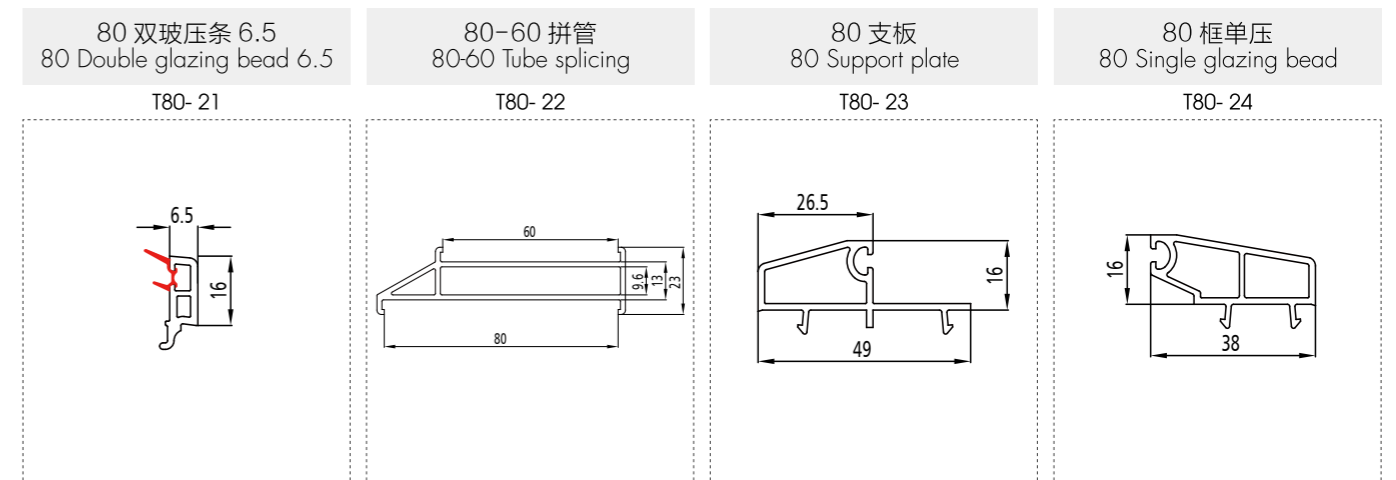

米重 Kg/m: 0.150  
每包支数 pcs/pac: 20

可共挤彩面 可共挤胶条  
Co-extrusion color surface  
Coextrusion rubber strip

米重 Kg/m: 0.470  
每包支数 pcs/pac: 10

可共挤彩面  
Co-extrusion color surface

米重 Kg/m: 0.310  
每包支数 pcs/pac: 10

可共挤彩面 可共挤胶条  
Co-extrusion color surface  
Coextrusion rubber strip

米重 Kg/m: 0.284  
每包支数 pcs/pac: 10

可共挤彩面 可共挤胶条  
Co-extrusion color surface  
Coextrusion rubber strip

注: 本公司可能随时进行技术升级, 订货时按技术部提供的图纸为准, 图样重量为基材理论重量, 实际重量以过磅时的重量为准。

# Section of profile

## 型材截面

# 80

## 推拉系列型材

### Push-pull Series Cross Section of Profile

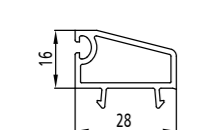
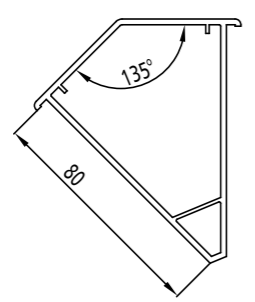
<p>80 框双压 80 Double glazing bead</p>	<p>80 135° 转角 80 135° The corner</p>
<p>T80- 25</p>	<p>T80- 26</p>
	
<p>米重 Kg/m: 0.250 每包支数 pcs/pac: 10</p>	<p>米重 Kg/m: 1.000 每包支数 pcs/pac: 4</p>
<p>可共挤彩面 Co-extrusion color surface</p>	<p>可共挤彩面 Co-extrusion color surface</p>

## 型材下料尺寸计算说明

### Description of Calculation of Cutting Size of Profile

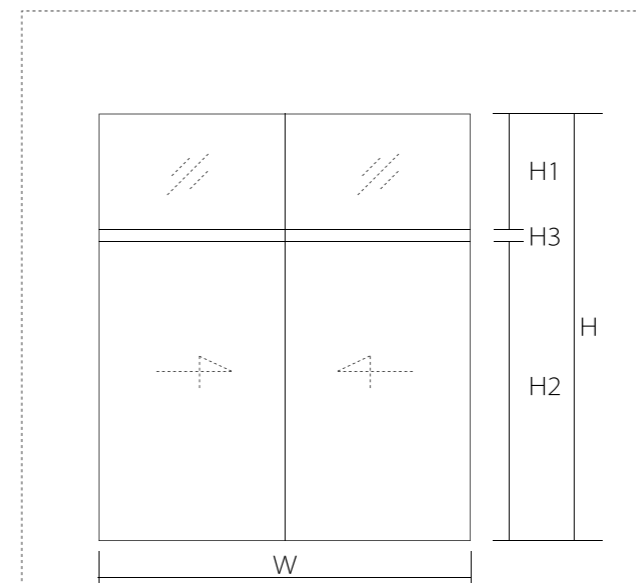

#### 推拉窗（门）下料尺寸计算

- (1) 上亮框高 =  $H1 + \text{焊接熔化量 } 6\text{mm}$
- (2) 上亮框宽 =  $W + \text{焊接熔化量 } 6\text{mm}$
- (3) 上亮框长 (第一根) =  $H1 - \text{框料} \times 2 + \text{梃料 (大面)} \times 2 + \text{焊接熔化量 } 6\text{mm}$
- (4) V口深度 =  $\text{框宽一半 (大面)} - \text{焊接熔化量 } 3\text{mm}$
- (5) 拼板长 =  $W$ , 厚度  $H3=2\text{mm}$
- (6) 推拉框宽 =  $W + \text{焊接熔化量 } 6\text{mm}$
- (7) 推拉框高 =  $H2 + \text{焊接熔化量 } 6\text{mm}$
- (8) 推拉扇宽 =  $W/2 - \text{框料} + \text{搭接量} + (\text{扇料} + \text{封边}) / 2 + \text{焊接熔化量 } 6\text{mm}$
- (9) 推拉扇高 =  $H2 - \text{框料} \times 2 + \text{搭接量} \times 2 + \text{焊接熔化量 } 6\text{mm} - \text{间隙 } 2\text{mm}$
- (10) 纱扇高 =  $H2 - \text{框料 (纱扇那面)} \times 2 + \text{搭接量} \times 2 + \text{焊接熔化量 } 6\text{mm}$

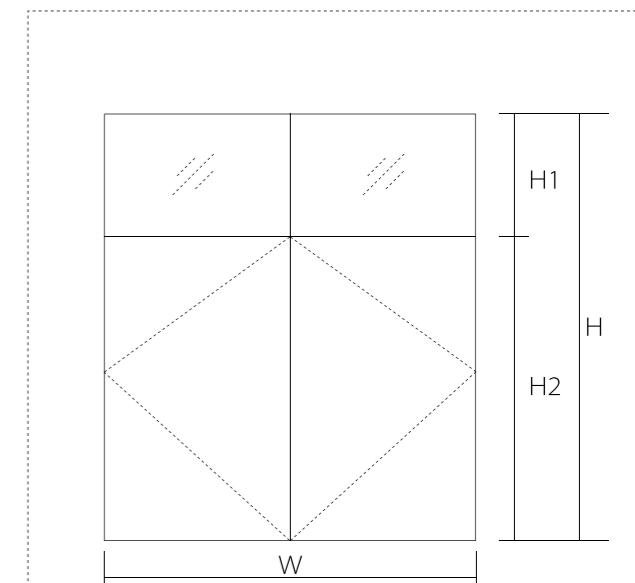

#### 平开窗下料尺寸计算

- (1) 外框高 =  $H + \text{焊接熔化量 } 6\text{mm}$
- (2) 外框宽 =  $W + \text{焊接熔化量 } 6\text{mm}$
- (3) 中横框 (第一锯) =  $W - \text{框料} \times 2 + \text{梃料 (大面)} \times 2 + \text{焊接熔化量 } 6\text{mm}$
- (4) V口深度 =  $\text{框宽一半 (大面)} - \text{焊接熔化量 } 3\text{mm}$
- (5) 上中竖框 (第一锯) =  $H1 - \text{框料} - \text{中横框 (大面)} / 2 + \text{梃料 (大面)} \times 2 + \text{焊接熔化量 } 6\text{mm}$
- (6) 下中竖框 (第一锯) =  $H2 - \text{框料} - \text{中横框 (大面)} / 2 + \text{梃料 (大面)} \times 2 + \text{焊接熔化量 } 6\text{mm}$
- (7) 平开扇宽 =  $W/2 - \text{框料 (小面)} - \text{梃料 (小面)} / 2 + \text{搭接量} \times 2 + \text{焊接熔化量 } 6\text{mm}$
- (8) 平开扇高 =  $H2 - \text{框料 (小面)} - 2 + \text{搭接量} \times 2 + \text{焊接熔化量 } 6\text{mm}$
- (9) 纱扇 (宽) 高 = 平开扇 (宽) 高

# Diversified window types

多元化的窗型



多元化的窗型，多种开启方式，完全满足您的个性化需求  
**功能与形态的最佳平衡，让门窗更加精彩绝伦**

## Luyang profiles

The best balance between function and form

鲁阳型材可与多种五金件配合，实现平开、推拉、折叠、内倒、上悬等以及异形门窗，以达到多种窗型及多元化的开启方式，实现了科技与形态美学的完美结合，达到功能与形态的最佳平衡。型材与五金件互相配合，达到了最佳效果，保证门窗的质量，满足用户的需求，让你的生活更加精彩绝伦。

Luyang profile can be matched with various hardware, so as to achieve various window types and diversified opening modes, realize the perfect combination of science and technology and morphological aesthetics, and achieve the best balance between function and morphology. Profile and hardware cooperate with each other to achieve the best effect, ensure the quality of doors and windows, meet the needs of users, and make your life more wonderful.

平开上悬系列  
Tilt-turn series



外悬窗系列  
Out-swinging window series



推拉上悬门系列  
Sliding top-hinged swing series



内开内倒系列  
Open inside and invert inside series



推拉及提升门窗系列  
Sliding series and left ,up & down



折叠门窗系列  
Folding door series



# Engineering case

## 部分工程案例

梦想孕育伟业，业绩印证辉煌，鲁阳凭借其稳定的产品品质，高性价比优势，项目利益高于一切的思想理念，专业认真的服务态度，赢得了市场的先机。鲁阳产品在全国各地的工程项目上得到广泛应用，并深受用户青睐。

Dream breeds great achievements, and performance proves brilliant. Luyang has won the market opportunities with its stable product quality, high cost performance advantage, the ideological concept that project interests are above all else, and professional and serious service attitude. Luyang products are widely used in engineering projects all over the country, and are favored by users.

### 部分工程案例 排名不分先后

- 金柱·月亮湾项目
- 孟达·德馨园项目
- 星光·山水文园项目
- 望湖安置小区项目
- 金柱·文苑项目
- 夕佳园老年公寓项目
- 明康·和馨园项目
- 北顺新城项目
- 金柱·水城华府项目
- 恒利公寓项目
- 尚东·苹果社区项目
- 朝阳花园项目
- 荣盛·西湖馨苑项目
- 城市主人高档小区项目
- 凤凰新城项目
- 湖景公寓项目
- 北川新城援建项目
- 拉萨火车站援建项目
- .....

另有多家用户，不再一一列举，在此一并鸣谢！



金柱·文苑项目



金柱·月亮湾项目



夕佳园老年公寓项目



望湖安置小区项目



# Engineering case

部分工程案例



城市主人高档小区项目



拉萨火车站援建项目



孟达·德馨园项目

# Service system

鲁阳服务体系

真诚服务每一支型材，用心做好每一个工程  
专业服务，创造价值

## Luyang profiles

Professional service, creating value

“一站式”，型材、门窗整体解决方案，充分满足客户集成化采购需求。快速响应、专业服务、持续改进、满足用户个性化需求。安全、快捷、经济的产品配送。正品、平价、便捷、全天候的技术支持及产品供应。

"One-stop", the overall solution of profiles, doors and windows, fully meet the needs of customers for integrated procurement. Quick response, professional service, continuous improvement, and meet the individual needs of users. Safe, fast and economical product distribution. Genuine, cheap, convenient, all-weather technical support and product supply.

